



N010NSPF - N020NE - N020NSP - N020NT

Specifications

Low level order picker

1.0 - 2.0 tonnes

Characteristics			Cat Lift Trucks	Cat Lift Trucks	Cat Lift Trucks	Cat Lift Trucks
1.01	Manufacturer (abbreviation)					
1.02	Manufacturer's model designation		NO10NSPF	NO20NE	NO20NSP	NO20NT
1.03	Power source: (battery, diesel, LP gas, petrol)		Battery	Battery	Battery	Battery
1.04	Operator type: pedestrian, (operator)-standing, -seated		Stand-on	Stand-on	Stand-on	Stand-on
1.05	Load capacity	Q (kg)	1000	2000	2000	2000
1.06	Load centre distance	c (mm)	600	600	600	600
1.08	Load wheel axle to fork face (forks lowered)	x (mm)	630	961	961	960
1.09	Wheelbase	y (mm)	1890	2040	2025	1928
Weight						
2.01	Truck weight with nominal load & maximum battery weight	kg	2150	2941	2980	2945
2.02	Axle loadings with nominal load & maximum battery weight, drive/load side	kg	720/1340	1072/1869	1010/1970	1022/1923
2.03	Axle loadings without load & with maximum battery weight, drive/load side	kg	710/440	662/349	655/325	719/226
Wheels, Drive Train						
3.01	Tyres: PT=Power Thane, Vul=Vulkollan, drive/load side		Vul/Vul	Vul/Vul	Vul/Vul	Vul/Vul
3.02	Tyre dimensions, drive side	(mm)	250 x 85	250 x 85	250 x 85	230 x 70
3.03	Tyre dimensions, load side	(mm)	85 x 75	85 x 75	85 x 75	85 x 75
3.04	Castor wheel dimensions (diameter x width)	(mm)	150 x 50	150 x 50	150 x 50	150 x 50
3.05	Number of wheels, drive/load side (x=driven)		2 + 1x/4	2 + 1x/4	2 + 1x/4	2 + 1x/4
3.06	Track width (centre of tyres), drive side	b10 (mm)	455	554	455	550
3.07	Track width (centre of tyres), load side	b11 (mm)	355	375	375	390
Dimensions						
4.02	Height with mast lowered (see tables)	h1 (mm)	1335	1335	1335	1510
4.04	Lift height (see tables)	h3 (mm)	800	115	115	115
4.08	Seat height	h7 (mm)	130	105	130	150
4.09	Height of tiller arm / steering console (min./max.)	h14 (mm)	1050/1160	1140/1220	1050/1160	1157/1349
4.14	Height of the driver's platform	h12 (mm)	130/930	130	130/930	150
4.15	Fork height, fully lowered	h13 (mm)	95	85	85	85
4.19	Overall length	l1 (mm)	2895	2412	2400	2330
4.20	Length to fork face (includes fork thickness)	l2 (mm)	1250	1262	1250	1180
4.21	Overall width	b1 / b2 (mm)	790	810	790	790
4.22	Fork dimensions (thickness, width, length)	s / e / l (mm)	65/165/1150	50/165/1150	50/165/1150	60/165/1150
4.25	Outside width over forks (minimum/maximum)	b5 (mm)	520	540	540	550
4.32	Ground clearance at centre of wheelbase, (forks lowered)	m2 (mm)	30	30	35	25
4.34/a	Working aisle width (Ast) with 800 x 1200 mm pallets, load lengthwise	Ast ⁽¹⁾ (mm)	3048	2903	2979	2600
4.34/b	Working aisle width (Ast3) with 800 x 1200 mm pallets, load lengthwise	Ast3 ⁽²⁾ (mm)	2860	2676	2664	2826
4.35	Turning circle radius	Wa (mm)	2090	2225	2225	2160
Performance						
5.01	Travel speed, with/without load	km/h	10/12	12/12	10/12	9.0/9.0
5.02	Lifting speed, with/without load	m/s	0.13/0.25	0.1/0.1	0.04/0.05	0.03/0.04
5.03	Lowering speed, with/without load	m/s	0.09/0.08	0.1/0.1	0.04/0.02	0.05/0.03
5.07	Gradeability, with/without load	%	7/15	7/15	7/15	10/15
5.10	Service brakes (mechanical/hydraulic/electric/pneumatic)		Electric	Electric	Electric	Electric
Electric motors						
6.01	Drive motor capacity (60 min. short duty)	kW	2.2	2.2	2.2	2.0
6.02	Lift motor output at 15% duty factor	kW	2.0	2.0	2.0	1.0
6.04	Battery voltage/capacity at 5-hour discharge	V/Ah	24/375, 465	24/375, 465	24/375, 465	24/240, 375
6.05	Battery weight	kg	280 - 360	280 - 360	280 - 360	205 - 300
Miscellaneous						
8.01	Type of drive control		Stepless	Stepless	Stepless	Stepless
8.04	Noise level, mean value at operator's ear (EN 12053)	dB(A)	64	63	64	64

1) Ast = Wa + R + 200
2) Ast3 = Wa - x + l6 + 200

Ast = Wa + R + a
Ast = Working aisle width
Wa = Turning radius
a = Safety clearance = 2 x 100 mm
R = $\sqrt{(l6 - x)^2 + (b12 / 2)^2}$

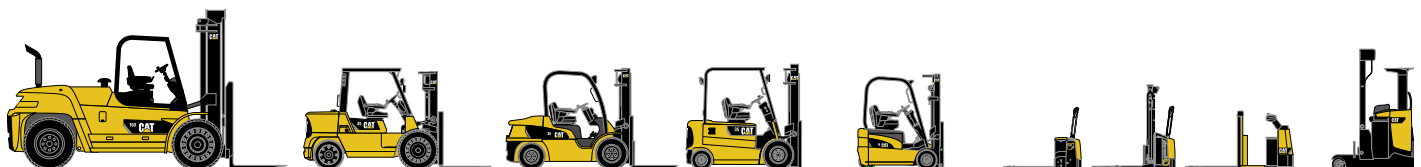

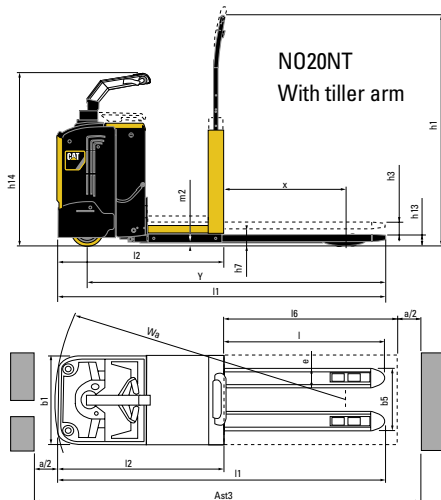
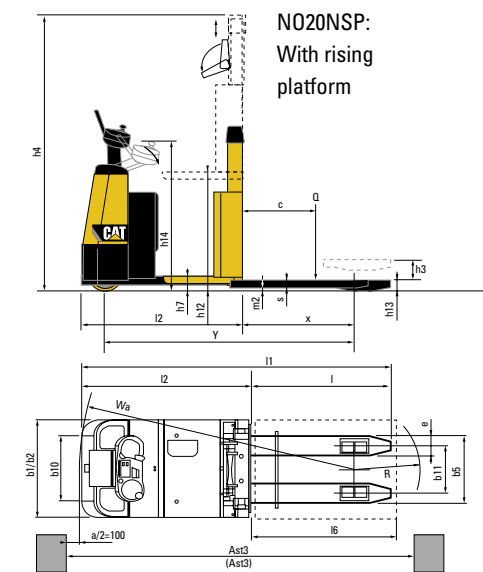
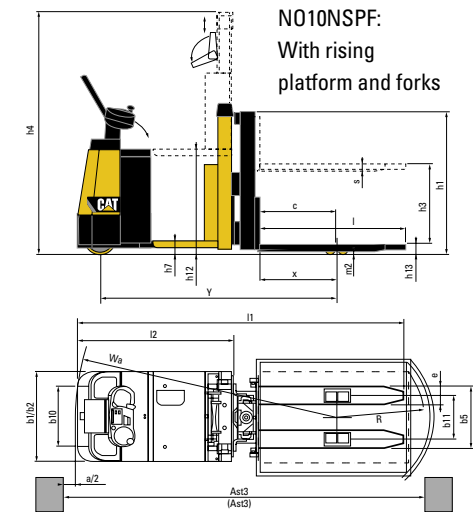
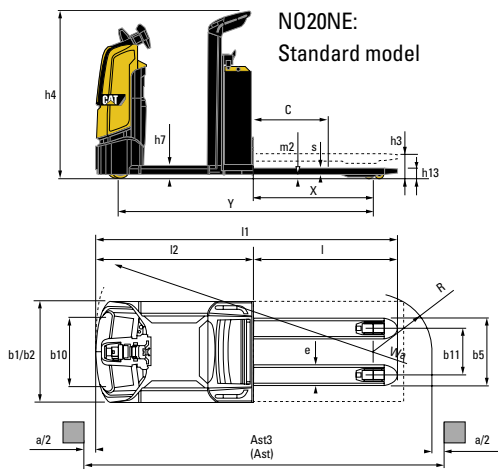

Lower Cost of Ownership

- Reduced maintenance costs due to longer service intervals of AC-drive technology combined with easy access to the battery compartment and motor components.
- Reduced brake wear resulting from regenerative braking.
- Fast troubleshooting for service engineers through the 'service' and 'fault code' memory functions.

Unmatched Productivity

Recent improvements to these trucks, such as faster acceleration and wider platforms, have resulted in a 13.6% increase in picking productivity against the previous AC-powered models.

These standard features are designed to aid operator concentration and allow high shift productivity:

- The re-positioned battery, behind the backrest, has created a spacious walk-through operator compartment for easy operation and repetitive on-off access.
- Smooth, progressive and easy-to-use controls in combination with comfortable, adjustable seat.
- NO20NSP and NO10NSPF feature a lifting platform making them ideal for first and second level picking heights.
- AC-drive technology provides smooth and comfortable operation.
- Fast acceleration and excellent maneuverability.
- Programmable features for different operators, optimizes performance level to match individual ability/experience.
- LCD display with easy-to-operate driver's menu showing all relevant information (driving speed, battery discharge, errors, warnings and service access).
- Foot operated button on NO20NSP and NO10NSPF for hands-free lowering of platform.
- Battery rollers for quick battery change.
- Rounded fork tips for smooth pallet entry, particularly when approaching at an angle.
- Tandem load wheels for easy entry into all types of pallets.

Safety and Ergonomics

Improved safety and comfort are at the heart of these trucks, with features such as:

- Maximum speed limit depending on load on forks.
- Improved steering wheel keeps all operating functions within reach of both hands, making it easy to drive 'backwards'.
- Electric, progressive steering gives precise control at speed.
- Bright white LED front lights with turn signal function for increased safety in dark areas.
- Automatic speed reduction in curves, for safe and secure handling.
- Automatic drive wheel centering at start-up and when leaving platform.
- Complete platform acts as a deadman's pedal so that the driver is correctly positioned during normal operation.
- Low step-in and spacious platform for quick on-off access.
- Angled tiller arm for comfortable operation (NO20NT).
- High backrest supports operator better and reduces fatigue.
- Clear display showing all relevant information.
- Rubber anti-slip floor mat.
- Foldable seat.
- Storage space for personal effects.

Options

- Walk-by-side drive buttons (except NO20NT) with built-in safety features.
- Transparent picking list / terminal holder (except NO20NT).
- Rubber bumper.
- Range of fork lengths for picking multiple pallet types or roll-containers.
- Electric power steering (NO20NT).
- Load weight indicator.
- Customizable side plates for company logo or artwork.
- Conventional 360° steering on NO20NE.

Cat® Lift Trucks.

Your partner in materials handling.



The NQ20NT low-level order picker is designed for fast and safe handling of orders from the picking face to despatch.

The truck exploits the benefits of AC motors such as precisely controllable power, stronger acceleration and longer service intervals than conventional DC motors.

The NQ20NT also incorporates a tiller arm made of strong but light aluminium. The soft, comfortable grips and smooth, easy controls make the truck easy to control and keeps the driver relaxed and productive, even over long shifts.

catliftruck@mcf.nl
www.catliftruck.com

WESC1074(02/09)ok
Copyright ©2009, MCFE. All rights reserved.
CATERPILLAR, CAT, their respective logos,
'Caterpillar Yellow' and the 'Power Edge' trade dress,
as well as corporate and product identity used
herein, are trademarks of Caterpillar and may not be
used without permission.

NOTE: Performance specifications may vary depending on standard manufacturing tolerances, vehicle condition, types of tyres, floor or surface conditions, applications, or operating environment. Trucks may be shown with non-standard options. Specific performance requirements and locally available configurations should be discussed with your Cat lift trucks Dealer. Cat Lift Trucks follows a policy of continual product improvement. For this reason, some materials, options and specifications could change without notice.

CAT® Lift
Trucks