



NTR30N

Specifications

Tow truck

3.0 tonnes



NTR30N

ADVANCED CONTROLS AND A SPACIOUS COMPARTMENT FOR EASE OF USE AND INCREASED PRODUCTIVITY.

The Cat® **NTR30N** is the tow truck of choice for many indoor towing applications, particularly in the automotive industry.

It benefits from a high top speed, fast acceleration and deceleration, long battery life, superb ergonomics, high maneuverability and built-in safety features which combine to provide the operator with a top quality, stress-free working environment.

A safe and productive operator environment

Based on our award winning Low-level order picker, the NTR30N gives the operator exceptional comfort and control, even over longer shifts.

The compartment is spacious with smooth edges for easy walk through and quick, repetitive on/off access.

The control panel features an LCD display with an easy-to-operate menu which keeps the operator aware of driving speed, battery discharge, errors and warnings.

Operators will find the 'F1' style steering wheel clusters the main controls within easy reach for operation with either hand, making 'driving backwards' easier.

Automatic drive wheel centering means the truck will always start in a straight line. Acceleration is smooth and controllable, while its short turning radius, progressive steering and automatic speed reduction in curves, ensures maximum controllability and maneuverability at any speed.

Featuring an anti-slip floormat, the full width 'dead-man' platform means each operator can find their most comfortable driving position, without having to keep a small pedal depressed.

For easy coupling and uncoupling of trailers, optional 'drive-by-side' controls allow 2-way movements, which is also a useful feature where the operator needs to walk between adjacent locations.

Characteristics			
1.01	Manufacturer (abbreviation)		Cat Lift Trucks
1.02	Manufacturer's model designation		NTR30N
1.03	Power source: (battery, diesel, LP gas, petrol)		Battery
1.04	Operator type: pedestrian, (operator)-standing, -seated		Standing
1.07	Rated drawbar pull	F (N)	600
1.09	Wheelbase	y (mm)	1256
Weight			
2.01	Truck weight with maximum battery weight	kg	900
2.03	Axle loadings without load & with maximum battery weight, drive/load side	kg	414/486
Wheels, Drive Train			
3.01	Tyres: PT=Power Thane, Vul=Vulkollan, drive/load side		Vul
3.02	Tyre dimensions, drive side		253x85
3.03	Tyre dimensions, load side		285x75
3.05	Number of wheels, drive/load side (x=driven)		1x/2
3.07	Track width (center of tyres), load side	b11 (mm)	710
Dimensions			
4.08	Seat- or stand height	h7 (mm)	105
4.12	Tow coupling height	h10 (mm)	75.5(+7x41.5)
4.19	Overall length	l1 (mm)	1613
4.21	Overall width	b1/b2 (mm)	810/610
4.32	Ground clearance at center of wheelbase, (forks lowered)	m2 (mm)	35
4.35	Turning circle radius	Wa (mm)	1450
Performance			
5.01	Travel speed, with/without load	km/h	See diagram
5.05	Drawbar pull, with/without load	N	See diagram
5.06	Max. drawbar pull, with/without load	N	3000
5.07	Gradeability, with/without load	%	5/15
5.10	Service brakes (mechanical/hydraulic/electric/pneumatic)		Electric
Electric motors			
6.01	Drive motor capacity (60 min. short duty)	kW	2.2
6.04	Battery voltage/capacity at 5-hour discharge	V/Ah	24/375-465
6.05	Battery weight	kg	280-375
Miscellaneous			
8.01	Type of drive control		AC
8.04	Noise level, mean value at operator's ear (EN 12053)	dB(A)	66

Stylish and ergonomic design

The modern styling features a well planned working compartment with smooth, rounded edges, wide access and anti-slip matting, that is designed to maximize comfortable and safe productivity. It's also environmentally friendly, with low energy consumption and uses recyclable materials, making it a 'green' addition to your warehouse fleet. The front cover panel, for instance, is made of polypropylene which is light but very strong and shock absorbing to protect against bumps.

Programmable settings for each operator

Keyless PIN Code access allows various performance levels, such as acceleration, top speed, etc. to be programmed for each individual driver.

Quick and easy to maintain

Your productivity will benefit from long service intervals of 600 hours and a service menu that features quick fault finding and fault code memory.

Behind the lift-off front panel, all components are within easy reach, including the simple to change, drive wheel. Everything is designed to keep maintenance downtime to only a necessary minimum, to keep the truck performing at its best.

Options

- Electric rear wheel brakes
- Side-mounted push-button drive controls
- Fold down seat for comfort when driving over longer distances
- 360° steering
- Battery changing device
- Customer name / logo / artwork on side panels

Find out how the NTR30N could work for you

Your Cat Lift Truck dealer can give you more specific information about the tow truck and also our full range of warehouse equipment and lift trucks, with capacities up to 16 tonnes.

They'll advise you on the right equipment for your needs and how to maximize your return on investment.

NTR30N

Tow truck.

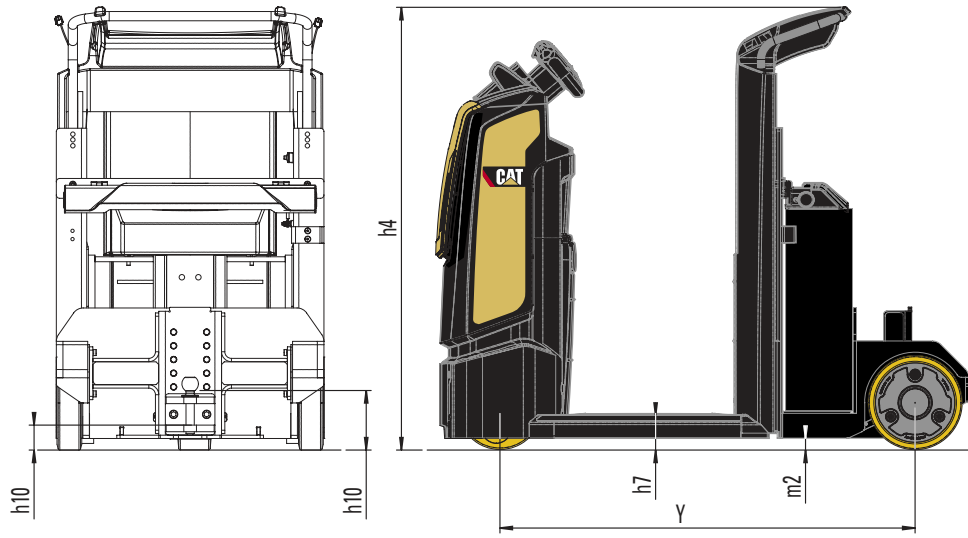

- Ast = $Wa + R + a$
- Ast = Working aisle width
- Wa = Turning radius
- a = Safety clearance = 2 x 100 mm
- R = $\sqrt{(l6 - x)^2 + (b12/2)^2}$

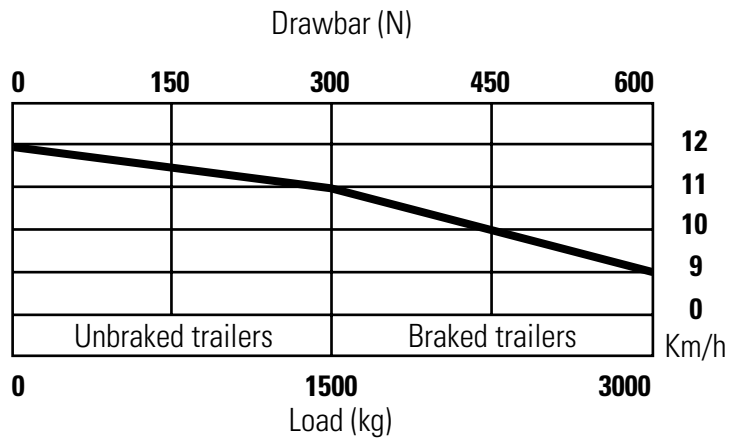
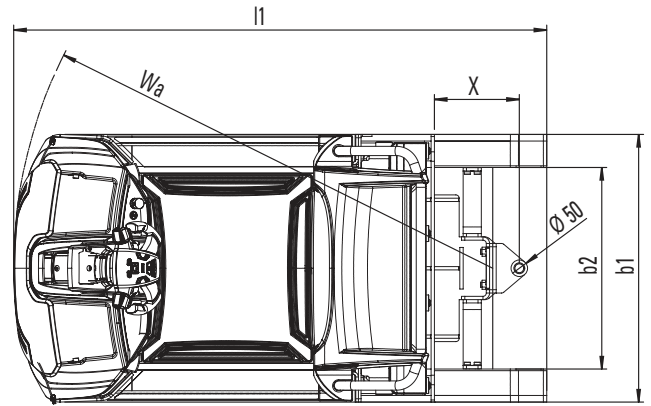

S2: 60min, Gradient 0%





NTR30N - The powerful tow truck from Cat Lift Trucks

Sample applications

- Automotive industry
- Auctions
- Intralogistics of non-palletized goods

Key benefits

- Towing capacity of trailers up to total weight of 3,000kg
- Height adjustable multifunctional tow coupling
- Spacious drive platform for easy on-off access
- Vibration damping anti-slip floormat
- AC drive motor & steering for smooth controllable power

- Multifunctional 'F1' style steering wheel for right or left hand operation
- Fast acceleration, deceleration and high top speed of 12 Km/h
- Progressive steering and speed control in curves for added safety
- Suspended drive unit for operator comfort and reduced component wear
- LED front lights with turn signal function for working in dimly lit areas
- CAN bus system for easy service and quick fault code finding/storage



Cat® Lift Trucks.

Your partner in materials handling.



For over 80 years Caterpillar has built some of the world's best construction and mining equipment, designed to perform in the toughest environments.

This same philosophy and heritage is evident in our materials handling equipment, which includes a complete range of electric, diesel and LPG powered lift trucks and warehouse equipment.

Every day our dealer network delivers tailored materials handling solutions in more than 70 Countries across Europe, Africa and the Middle East.

We continually invest in the selection, development and support of our dealer network to provide you with the right equipment, service and advice. For instance, we offer the highest parts availability in the industry of over 97%, measured full line first pick, with next day delivery in most Countries.

Come and talk to us about your materials handling requirements.

Contact your dealer now or visit our website:

www.catliftruck.com.

Cat Lift Trucks.

PERFORMANCE DURABILITY CUSTOMER SERVICE

info@catliftruck.com

www.catliftruck.com

WEGC1186(02/11)ok
Copyright ©2009, MCFE. All rights reserved.
CAT, CATERPILLAR their respective logos,
'Caterpillar Yellow' and the 'Power Edge' trade dress,
as well as corporate and product identity used herein,
are trademarks of Caterpillar and may not be used
without permission.
Printed in The Netherlands

NOTE: Performance specifications may vary depending on standard manufacturing tolerances, vehicle condition, types of tyres, floor or surface conditions, applications, or operating environment. Trucks may be shown with non-standard options. Specific performance requirements and locally available configurations should be discussed with your Cat lift trucks Dealer. Cat Lift Trucks follows a policy of continual product improvement. For this reason, some materials, options and specifications could change without notice.

CAT® Lift
Trucks